

Surface Mount Fuses
Type 172876

quick-acting F

directly solderable on printed circuit boards or plugable into surface mount fuseholder

Oberflächenmontierbare Sicherungen
Typ 172876

flink F

direkt einlötlbar auf Leiterplatten oder steckbar in oberflächenmontierbare Sicherungshalter



1:1

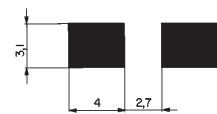
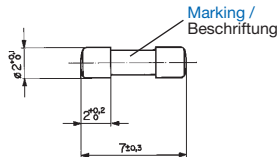

Solder pad / Anschlussflächen

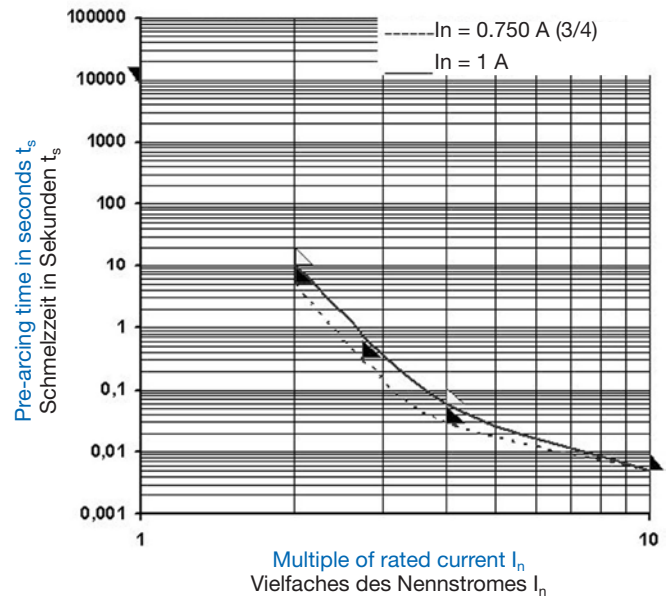
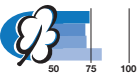

Standards / Normen

UL 248-14

Approvals / Approbationen



Pre-arcing time/current characteristic (at T_a 23 °C)

Zeit-Strom-Charakteristik (bei T_u 23 °C)

$n \cdot I_n$	$1 \cdot I_n$	$2 \cdot I_n$	$2,75 \cdot I_n$	$4 \cdot I_n$	$10 \cdot I_n$
$< 750\text{ mA}$	$t \geq 4\text{ h}$	$t \leq 5\text{ s}$	$t \leq 300\text{ ms}$	$t \leq 30\text{ ms}$	$t \leq 5\text{ ms}$
$\geq 1\text{ A}$	$t \geq 4\text{ h}$	$t \leq 10\text{ s}$		$t \leq 60\text{ ms}$	$t \leq 5\text{ ms}$

Order No. / Bestell-Nr.	Rated current I_n / Rated voltage U_n / Nennstrom I_n / Nennspannung U_n	Breaking capacity / Ausschaltvermögen	Voltage drop / Spannungsfall at / bei I_n	Sustained power dissipation / Verlustleistung at / bei $1 \cdot I_n$	Pre-arcing I^2t / Schmelz I^2t at / bei $10 \cdot I_n$	Approvals / Approbationen
			max. mV	max. mW	A^2s	
7010.9750.XX	63 mA / 125 V	300 A / 125 V AC/DC $\cos \varphi = 1$ L/R = 1 ms	590	37	0,00022	UL CSA
7010.9760.XX	125 mA / 125 V		640	80	0,0024	
7010.9770.XX	250 mA / 125 V		275	69	0,0061	
7010.9780.XX	375 mA / 125 V		215	81	0,012	
7010.9790.XX	500 mA / 125 V		205	103	0,046	
7010.9800.XX	750 mA / 125 V		190	143	0,09	
7010.9810.XX	1 A / 125 V		180	180	0,11	
7010.9820.XX	1,5 A / 125 V		185	278	0,25	
7010.9830.XX	2 A / 125 V		160	320	0,72	
7010.9840.XX	2,5 A / 125 V		160	400	0,91	
7010.9850.XX	3 A / 125 V		155	465	1,3	
7010.9860.XX	3,5 A / 125 V		145	510	1,7	
7010.9870.XX	4 A / 125 V		140	560	2,6	
7010.9880.XX	5 A / 125 V		125	625	4	
7010.9890.XX	7 A / 125 V		120	840	8,5	
7010.9892.XX	10 A / 65 V	300 A / 65 V AC/DC $\cos \varphi = 1$ L/R = 1 ms	110	1100	31	
7010.9894.XX	12 A / 65 V		115	1380	48	
7010.9896.XX	15 A / 65 V		105	1575	92	

.XX Packaging index / Verpackungsindex

Surface Mount Fuses Type MKF
quick-acting F

directly solderable on printed circuit boards

Oberflächenmontierbare Sicherungen Typ MKF

flink F

direkt einlötlbar auf Leiterplatten



1:1

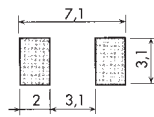
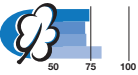
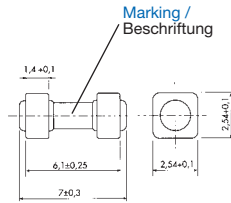

Solder pad / Anschlussflächen

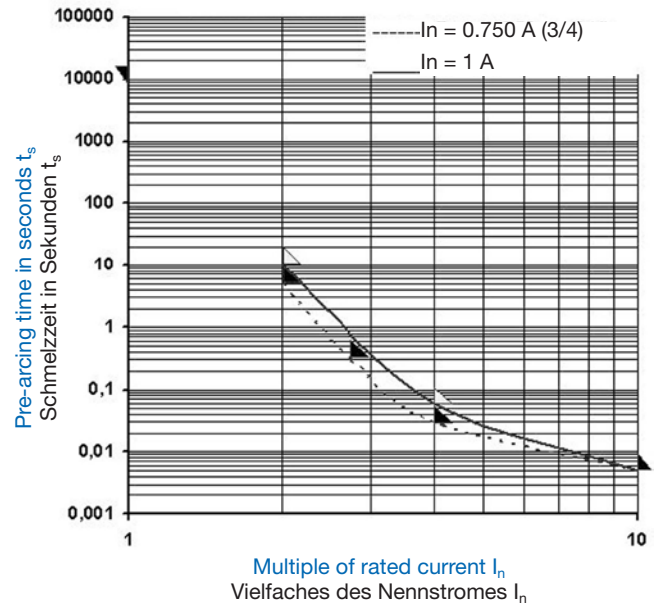

Standards / Normen

UL 248-14

Approvals / Approbationen



Pre-arcing time/current characteristic (at T_a 23 °C)

Zeit-Strom-Charakteristik (bei T_u 23 °C)

Rated current I _n / Nennstrom I _n	n · I _n				
	1 · I _n	2 · I _n	2,75 · I _n	4 · I _n	10 · I _n
I _n ≤ 3/4 A	t ≥ 4 h	t ≤ 5 s	t ≤ 300 ms	t ≤ 30 ms	t ≤ 5 ms
I _n ≥ 1 A	t ≥ 4 h	t ≤ 10 s		t ≤ 60 ms	t ≤ 5 ms

Order No. / Bestell-Nr.	Rated current I _n / Rated voltage U _n / Nennstrom I _n / Nennspannung U _n	Breaking capacity / Ausschaltvermögen	Voltage drop / Spannungsfall at / bei I _n max.	Sustained power dissipation / Verlustleistung at / bei 1 · I _n	Pre-arcing I ² t / Schmelz I ² t at / bei 10 · I _n	Approvals / Approbationen
			mV	max. mW	A ² s	UL CSA
7010.9900.XX	63 mA / 125 V	300 A / 125 V AC/DC p.f. / cos φ = 1 L/R = 1 ms	505	32	0,00022	
7010.9901.XX	125 mA / 125 V		590	74	0,0024	• •
7010.9902.XX	250 mA / 125 V		235	59	0,0061	• •
7010.9903.XX	375 mA / 125 V		205	77	0,012	• •
7010.9904.XX	500 mA / 125 V		190	95	0,046	• •
7010.9905.XX	750 mA / 125 V		170	128	0,09	• •
7010.9906.XX	1 A / 125 V		155	155	0,11	• •
7010.9907.XX	1,5 A / 125 V		160	240	0,25	• •
7010.9908.XX	2 A / 125 V		150	300	0,72	• •
7010.9909.XX	2,5 A / 125 V		145	363	0,91	• •
7010.9910.XX	3 A / 125 V		145	435	1,3	• •
7010.9911.XX	3,5 A / 125 V		140	490	1,7	• •
7010.9912.XX	4 A / 125 V		135	540	2,6	• •
7010.9913.XX	5 A / 125 V		125	625	4	• •
7010.9914.XX	7 A / 125 V	125	875	8,5	• •	
7010.9915.XX	10 A / 65 V	300 A / 65 V AC/DC p.f. / cos φ = 1 L/R = 1 ms	110	1100	31	
7010.9916.XX	12 A / 65 V		110	1320	48	
7010.9917.XX	15 A / 65 V		100	1500	92	

.XX Packaging index / Verpackungsindex

Additional technical data / Zusätzliche technische Daten

Ambient temperature max. T_a / Zulässige Umgebungstemperatur T_u	- 55 °C ÷ + 85 °C
Solderability; Reflow-(infra-red and vapour phase) and wave soldering / Lötbarkeit; Reflow-(Infrarot- und Dampfphase) und Wellenlötung	235 °C / 2 sec. IEC 60068-2-58 / test / Test Td
Soldering heat resistance / Lötwärmebeständigkeit	260 °C / 10 sec. IEC 60068-2-58 / test / Test Td
Materials: Housing Terminals Werkstoffe: Gehäuse Anschlüsse	Ceramics Brass, tin-plated Keramik Cu Zn verzinkt
Net weight % / Nettogewicht %	172876, MSB = 7 g for / für 100 pieces / Stk. MKf, MKT = 14,5 g for / für 100 pieces / Stk.

Packaging / Verpackung:

Types / Typen 172876 and / und MSB

Tube or tape / Röhrcchen oder Gurt	
Tube of 100 pieces / Röhrcchen à 100 Stück, lose geschüttelt	7010.XXXX.63
Taped and reeled 1500 pieces / Blistergurt à 1500 Stück auf Rolle	7010.XXXX.57
Taped and reeled 5000 pieces / Blistergurt à 5000 Stück auf Rolle	7010.XXXX.59

Types / Typen MKF and / und MKT

Bag or tape / Beutel oder Gurt	
Bag of 100 pieces / Beutel à 100 Stück	7010.XXXX.03
Taped and reeled 1500 pieces / Blistergurt à 1500 Stück auf Rolle	7010.XXXX.57

Blisertape and reel / Blistergurt und Rolle

according to IEC 60286-3 / gemäss IEC 60286-3

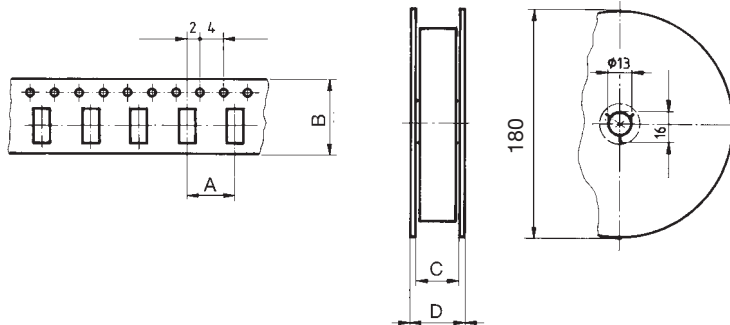

Types / Typen	Dimensions / Masse in mm			
	A	B	C (max.)	D (max.)
172876	4	12	12,4	18,4
MSB				
MKF				
MKT				



Suitable surface mount fuseholder see page 177 /
Passender oberflächenmontierbarer
Sicherungshalter siehe Seite 177

Additional technical data / Zusätzliche technische Daten

Ambient temperature max. T_a / Zulässige Umgebungstemperatur T_u	- 55 °C ÷ + 85 °C
Solderability; Reflow-(infra-red and vapour phase) and wave soldering / Lötbarkeit; Reflow-(Infrarot- und Dampfphase) und Wellenlötung	235 °C / 2 sec. IEC 60068-2-58 / test / Test Td
Soldering heat resistance / Lötwärmebeständigkeit	260 °C / 10 sec. IEC 60068-2-58 / test / Test Td
Materials: Housing Terminals Werkstoffe: Gehäuse Anschlüsse	Ceramics Brass, tin-plated Keramik Cu Zn verzinkt
Net weight % / Nettogewicht %	172876, MSB = 7 g for / für 100 pieces / Stk. MKf, MKT = 14,5 g for / für 100 pieces / Stk.

Packaging / Verpackung:

Types / Typen 172876 and / und MSB

Tube or tape / Röhrcchen oder Gurt	
Tube of 100 pieces / Röhrcchen à 100 Stück, lose geschüttelt	7010.XXXX.63
Taped and reeled 1500 pieces / Blistergurt à 1500 Stück auf Rolle	7010.XXXX.57
Taped and reeled 5000 pieces / Blistergurt à 5000 Stück auf Rolle	7010.XXXX.59

Types / Typen MKF and / und MKT

Bag or tape / Beutel oder Gurt	
Bag of 100 pieces / Beutel à 100 Stück	7010.XXXX.03
Taped and reeled 1500 pieces / Blistergurt à 1500 Stück auf Rolle	7010.XXXX.57

Blisertape and reel / Blistergurt und Rolle

according to IEC 60286-3 / gemäss IEC 60286-3

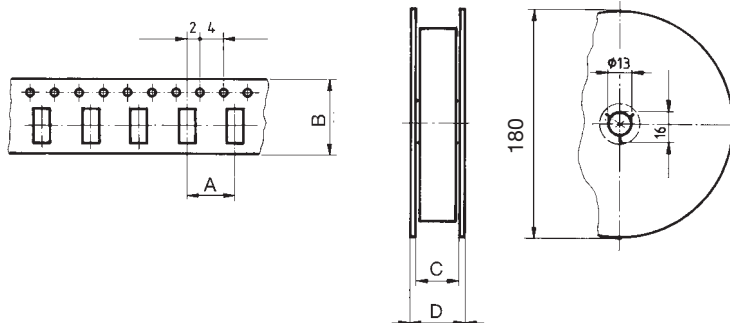

Types / Typen	Dimensions / Masse in mm			
	A	B	C (max.)	D (max.)
172876	4	12	12,4	18,4
MSB				
MKF				
MKT				



Suitable surface mount fuseholder see page 177 /
Passender oberflächenmontierbarer
Sicherungshalter siehe Seite 177